

SLURRY MIXING TANKS

Direct Driven Model

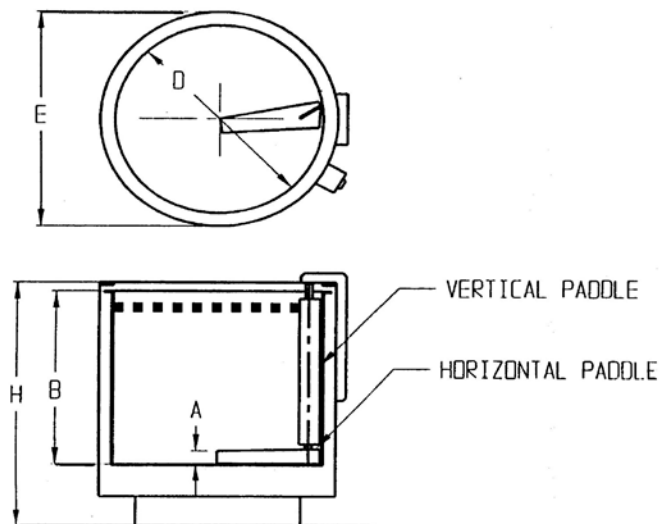

STANDARD FEATURES

- Removable, L-shaped paddle
- On/off switch
- Overload protection

OPTIONS

- Variable Speed
- Remote Start/Stop
- Water Cooling
- Temperature Controls
- Zero speed detection (alarm)
- Slurry level sensing
- Automatic cover
- Plastic liner
- Full plastic tank

TANK SIZE D	E	A	B	H	SLURRY VOLUME	
					LITRE	US GAL
24" 610mm	28" 710mm	2.5" 64mm	27" 685mm	37.75" 960mm	185	49
30" 760mm	34" 870mm	2.75" 70mm	28" 710mm	38.75" 985mm	300	78
32" 810mm	36" 910mm	2.75" 70mm	29" 735mm	40" 1015mm	353	93
36"-L 915mm	40" 1016mm	3" 75mm	25" 635mm	38.75" 985mm	380	100
36"-H 915mm	40" 1016mm	3" 75mm	30" 762mm	43.5" 1104mm	465	122
47.5" 1200mm	52.7" 1340mm	3.8" 96mm	41.6" 1056mm	57.5" 1460mm	1085	285

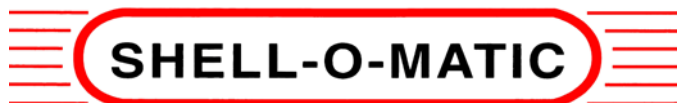

10600 Ste Gertrude Blvd., Montreal North, Quebec H1G 5N4 Canada

Tel: +514 323-0868

Fax: +514 329-3672

Email: info@shellomatic.com

Website: www.shellomatic.com